

VAIO
no more bounds



Intel® Centrino™ Mobile Technology

Aesthetic attraction. Elite architecture.



VAIO S
VGN-S58GP/B

like.no.other

SONY

Specifications

Model	VGN-S58GP/B
Platform	Intel® Centrino™ Mobile Technology • Intel® Pentium® M Processor 770 (2.13GHz) ¹ • Intel® PRO/Wireless 2200BG Network Connection • Intel® 915PM Express Chipset
Operating System	Microsoft® Windows® XP Professional with Service Pack 2 (English version) Multilingual User Interface (pre-installed Traditional Chinese)
Processor System Bus	533MHz
Memory Bus	533MHz
Cache Memory	L1 Cache: 64KB L2 Cache: 2MB (on CPU)
Main Memory	512MB DDR2 SDRAM ² (upgradeable up to 2GB) ³ (partially shared with video memory) ⁴ 2 SO-DIMM slots (The pre-installed memory module uses one)
Hard Disk	80GB (C: 20GB, D: 60GB) ⁵ Serial ATA, 5400rpm
Optical Drive	DVD±RW Drive (supporting DVD+R Double Layer disc) ⁶ Maximum reading speed: DVD+R, DVD-R, DVD+RW, DVD-RW, DVD+R DL (Double Layer): 4x / DVD-ROM: 8x / CD-RW: 12x / CD-R, CD-ROM: 24x Maximum writing speed: DVD+R, DVD-R: 4x / DVD+RW, DVD+R DL (Double Layer): 2.4x / DVD-RW: 2x / CD-RW: 10x / CD-R: 24x
Graphics Accelerator	• Dual display compatible • 3D graphics acceleration compatible • NVIDIA® GeForce™ Go 6400 with TurboCache™ ⁴ (PCI Express x16 connection)
Video Memory	128MB ⁴
Display	13.3" Wide (WXGA: 1280 x 800) TFT colour display (Clear Bright LCD: Single Lamp, Wide View)
Interfaces	• USB 2.0 x 2 ⁷ • i.LINK (IEEE 1394) S400 (4 pin) • Network (RJ-45) connector (100BASE-TX/10BASE-T) • Headphone jack (stereo mini) • Microphone jack (stereo mini) • Monitor connector (VGA, D-SUB 15 pin) • Modular (RJ-11) connector • Port Replicator connector • Memory Stick Slot ⁸ (Standard/Duo Size compatible, MagicGate compatible, Memory Stick PRO compatible ⁹ , High-speed data transfer compatible)
Wireless LAN	• Integrated Wireless LAN IEEE 802.11b/802.11g ¹⁰ • Intel® PRO/Wireless 2200BG Network Connection • Data rate: maximum 11Mbps (802.11b) 54Mbps (802.11g) ¹¹ • Frequency: 2.4GHz
Bluetooth®	• Bluetooth® standard version 2.0+EDR • Output: maximum +6dBm • Frequency: 2.4GHz
Modem	V.92 and V.90 Compliant
PC Card Slot	Type I/II x 1, CardBus Support
Audio	• Intel® High Definition Audio compatible • 3D audio (Direct Sound 3D support) • Built-in stereo speakers
Keyboard / Input Device	• ca 18mm Key pitch / ca 2mm Key stroke • 82 Keys • Intelligent Touchpad
Battery	VGP-BPS2 ¹² Lithium-ion battery: up to 3.5 hours of use ¹³
Dimensions (W x H x D)	312.5 x 29.9-35.4 x 224.8mm
Weight	1.95kg (including the supplied battery)
Software Applications	• Adobe Reader 7 • Adobe Photoshop Elements 3.0 (Installer) • Adobe Premiere Standard • Click to DVD 2.4 • DVgate Plus 2.1 • Norton Internet Security 2005 • Roxio DigitalMedia SE 7 • PictureGear Studio 2.0 • SonicStage 3.2 • SonicStage Mastering Studio 1.4 • SonicStage Mastering Studio Audio Filter 1.4 • VAIO Control Center 1.1 • VAIO Edit Components 5.0 • VAIO Media 4.1 • VAIO Original Screen Saver • VAIO Recovery Utility 2.5 • VAIO Update 2.1 • VAIO Zone 1.4 • WinDVD 5 for VAIO
Supplied Accessories	• AC adapter (VGP-AC19V10) • Lithium-ion battery (VGP-BPS2)
Warranty	One year ¹⁴

Features and specifications are subject to change without notice.

¹ CPU speed will be reduced under certain operating conditions. ² If memory modules of the same capacity are installed to both of the two memory module slots, computer will run in dual channel mode and provide better performance. ³ By removing the pre-installed 512MB memory module and adding two 1GB memory modules. ⁴ NVIDIA® TurboCache™ technology combines the size and bandwidth of video memory and dynamically available system memory for optimal system performance. ⁵ Includes necessary data for recovery (setting back to initial shipment settings) in the hard disk drive consuming approximately 5GB in size. ⁶ This product is designed to playback discs that conform to the Compact Disc Digital Audio standard specifications (CD Standard). A DualDisc is a two sided disc product which mates DVD recorded material on one side with digital audio material on the other side. Please be aware that the audio side (non-DVD side) of a DualDisc may not play on this product because it does not conform to the CD Standard. ⁷ High-speed/Full-speed/Low speed compatible. ⁸ Compatibility confirmed with Sony branded "Memory Stick" media only. ⁹ MagicGate copyright protection technology cannot be applied to Memory Stick PRO. ¹⁰ Deploying IEEE 802.11b and IEEE 802.11g products on the same wireless network may reduce the communication speed due to radio interference. Taking this into consideration, the IEEE 802.11g products are designed to reduce the communication speed to ensure communication with IEEE 802.11b products. When the communication speed is not as fast as expected, changing the wireless channel on the access point may increase the communication speed. ¹¹ The communication speed varies depending on the distance between communication devices, existence of obstacles between such devices, the device configuration, the radio conditions, and the software in use. In addition, communication may be cut off depending on the radio conditions. ¹² This product may only function with a genuine Sony battery designed for this model. ¹³ Estimated battery life (under JEITA Battery Run Time Measurement Method (ver.1.0)) When the power-saving mode is on. Actual battery life may vary with different operating conditions and settings. For further details, please visit vaio-online.sony.com ¹⁴ Warranty conditions may vary by region.

The trademarks, including but not limited to "SONY", "VAIO", "Memory Stick" and "SonicStage" are either trademarks or registered trademarks of Sony Corporation and/or its subsidiaries. Adobe, Adobe Photoshop, Adobe Reader and Adobe Premiere are trademarks of Adobe Systems Incorporated in the United States and/or other countries. Intel, Intel logo, Intel Inside, Intel Inside logo, Intel Centrino, Intel Centrino logo, Intel SpeedStep, and Pentium are trademarks or registered trademarks of Intel Corporation or its subsidiaries in the United States and other countries. Microsoft and Windows are either trademarks or registered trademarks of Microsoft Corporation in the United States and other countries. All other product and brand names may be trademarks or registered trademarks of their respective owners. Whilst information given is true at time of printing, small production changes in the course of our company's policy of improvement through research and design might not necessarily be included in the specifications. E&OE. Actual models may differ slightly in appearance to illustrations provided.

Optional Accessories (availability depends on region)

VGP-PRS2 Port Replicator

- Monitor connector (DVI-D)
- Monitor connector (VGA, D-SUB 15 pin)
- Printer connector
- Network connector
- USB 2.0 connector (x3)



VGP-BPL2 Lithium-ion Battery

- Rechargeable battery



VGP-AC19V10 AC Adapter

- Universal voltage compatible: AC100 - 240V



VGP-UMS50 USB Optical Mouse

- Stylish, easy-to-use sloping design
- Innovative PTFE sole for precise operation
- Sensor resolution: 800 dots per inch



PCGA-UMS3/B USB Optical Mouse (Compact)

- Sophisticated, dynamic exterior
- Maintenance-free optical design
- Sensor resolution: 800 dots per inch



VGP-CKS1 Carrying Case

- Suitable size just for VAIO S
- Durable nylon outer material
- Soft lining prevents scratches
- Stylish VAIO logo accent



Sony recommends Microsoft® Windows® XP Professional.

VGN-S58GP/B

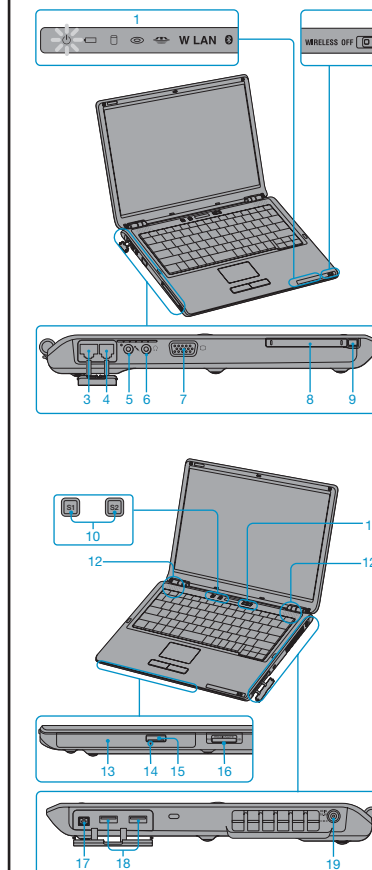

1. Indicators
2. Wireless LAN switch
3. Network (RJ-45) connector (100BASE-TX/10BASE-T)
4. Modular (RJ-11) connector
5. Microphone jack (stereo mini)
6. Headphone jack (stereo mini)
7. Monitor connector (VGA, D-SUB 15 pin)
8. PC Card slot (Type I/II x 1)
9. PC Card eject button
10. Shortcut buttons
11. Power button
12. Built-in stereo speakers
13. DVD±RW drive (supporting DVD+R Double Layer disc)
14. Manual eject hole
15. Disc eject button
16. Memory Stick Slot (Standard/Duo Size, MagicGate, Memory Stick PRO, high-speed data transfer compatible)
17. i.LINK (IEEE 1394) S400 (4 pin) connector
18. USB 2.0 connector (x2)
19. DC-IN connector

vaio-online.sony.com



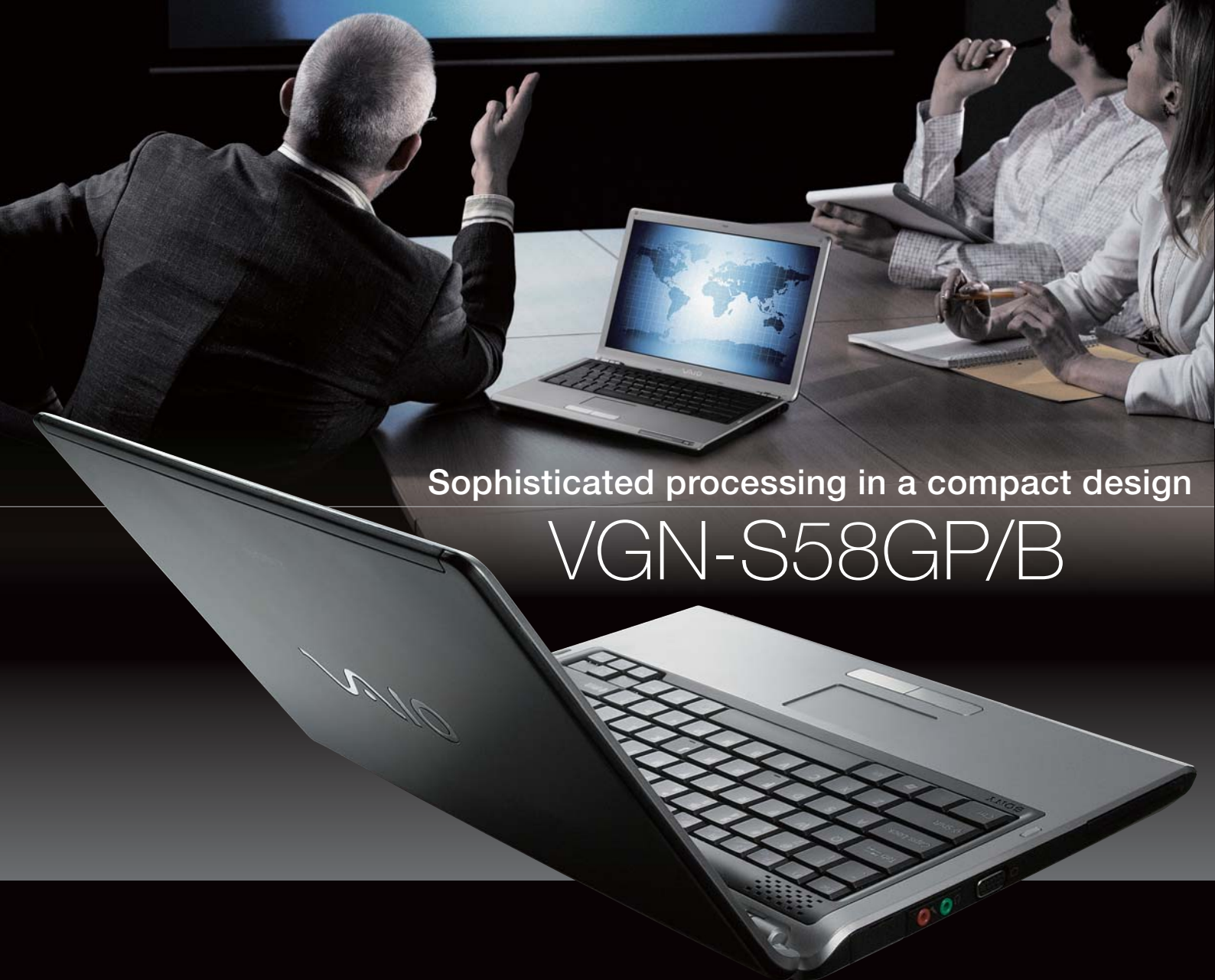

Sophisticated processing in a compact design

VGN-S58GP/B

Sony recommends Microsoft® Windows® XP Professional.

13.3" wide LCD for optimal viewing

The VAIO S58GP/B gives you several choices for premium display of software applications. With the 13.3" wide (WXGA: 1280 x 800) LCD, you can view an open task menu on the right with plenty of space remaining for a wide operation area on the left. Or conveniently arrange the horizontal layout of two application windows to be opened at the same time. Whether working with separate documents or taking advantage of help menus, the versatile 13.3" wide LCD of the VAIO S58GP/B has a broad range of excellent options you need for serious work.



Latest Intel® Centrino™ Mobile Technology

Advanced Intel® Centrino™ Mobile Technology is your assurance of smooth and powerful response. This technology is comprised of Intel® Pentium® M Processor 770 (2.13GHz), the latest advanced chipset (Intel® 915PM Express Chipset) supported by FSB 533MHz, and Intel® PRO/Wireless 2200BG Network Connection. In addition, the 80GB HDD (5400rpm) Serial ATA, and 512MB DDR2 SDRAM (533MHz) main memory are incorporated to fully experience the advantages of your VAIO S58GP/B.

DVD entertainment at its finest

For genuine DVD editing and viewing pleasure, the VAIO S58GP/B is most entertaining. Click to DVD lets you make an original DVD movie in one click with your choice of DVD±R/RW or DVD+R Double Layer disc. The Clear Bright LCD provides distinctly beautiful images, while the 13.3" wide (WXGA: 1280 x 800) screen lets you enjoy DVD movies and other wide AV content at optimum size through VAIO Zone's single interface. Then, Dolby Virtual Speaker* and Dolby Headphone* technology give you virtual 5.1 surround sound. Supported by the sophisticated NVIDIA® GeForce™ Go 6400 with TurboCache™** external graphics accelerator, 128MB** of video memory, and PCI Express x 16 connection, all these features deliver a cinema-like experience. See how truly entertaining your VAIO S58GP/B can be!

* Dolby Virtual Speaker and Dolby Headphone functions are only available when WinDVD 5 for VAIO or VAIO Zone is used.
** NVIDIA® TurboCache™ technology combines the size and bandwidth of video memory and dynamically available system memory for optimal system performance.



Sony's recommended headphones* for VAIO

Inner, Open-air MDR-E931LP	Overhead, Open-air MDR-Q22LP
Inner, Closed MDR-EX51LP	Overhead, Closed MDR-V700DJ

VAIO provides an audio filter adjusted exclusively for the recommended headphones. Created at a professional music studio, this filter ensures superlative quality sound reproduction.
* Availability depends on region.

Looking for an ideal notebook PC? The stylish VAIO S58GP/B offers the latest Intel® Centrino™ Mobile Technology with a superior Intel® Pentium® M processor 770 to deliver sophisticated high performance within a lightweight body. Ample 80GB HDD (Serial ATA, 5400rpm) capacity combines with an advanced graphics chip, wireless and DVD creation capabilities and a full-sized keyboard — making it easier to satisfy all your demands. And the 13.3" wide screen offers generous space for several application windows at a time. Highly compact, yet surprisingly powerful, the VAIO S58GP/B has the advanced architecture and the right size for uses ranging from business to home entertainment.



- Full-sized keyboard with pearl-painted palm rest area
- Solid magnesium & mirror VAIO logo
- Slim slanted design
- Simple functional buttons
- Latchless locking hinge
- Half-mirror LEDs

Main features

DVD video recording: One-Click DVD Video Creation	Beautiful viewing: Clear Bright LCD (Single Lamp, Wide View) / Wide 16:10	Light for its size: 1.95kg	Network freedom: Wireless LAN 802.11 b/g	Cable-free: Bluetooth®	High quality: 2-sided Magnesium Body	Handy presentation: Plug & Display
Comfortable typing: Full-sized Keyboard	Content sharing: Memory Stick Slot (Standard/Duo/PRO/MagicGate compatible)	Theatre sound quality: Dolby Virtual Speaker / Dolby Headphone	Optional accessory: Port Replicator			

Basic specifications

Intel® Pentium® M Processor 770 (2.13GHz)	Microsoft® Windows® XP Professional	13.3" WXGA 1280 x 800 LCD	GeForce™ Go 6400 with TurboCache™* (128MB*)	DVD±RW Drive (supporting +R DL)	512MB (DDR2) Main Memory	80GB Hard Disk Drive (Serial ATA, 5400rpm)
---	-------------------------------------	---------------------------	---	---------------------------------	--------------------------	--

* NVIDIA® TurboCache™ technology combines the size and bandwidth of video memory and dynamically available system memory for optimal system performance.

Built-in Bluetooth® for smooth, cable-free communication

The VAIO S58GP/B comes with built-in Bluetooth® standard version 2.0+EDR that enhances data transfer speed while minimising power consumption. The VAIO S58GP/B also supports a headset profile that lets you use Bluetooth®-compatible headsets with various applications and enjoy smooth voice communication during business and social calls.

Recommended headset



Sony Ericsson HBH-608*

* Availability depends on region.

Powerful software for creative minds.

DVD CREATION

With Click to DVD, you're only a click away from creating your own photo, movie + photo, or video DVD on DVD±R/RW or DVD+R Double Layer disc. You can also create 5.1 surround sound DVDs. Moreover, Roxio DigitalMedia SE lets you back up audio, image, and data files on CDs and DVDs.



Roxio DigitalMedia SE

CONTENT BROWSER

VAIO Zone lets you seamlessly enjoy CDs, DVDs, music, photos, videos and other AV files through a single interface. And VAIO Media software enables AV files on your VAIO to be accessed and played by other VAIO Media-installed VAIO notebooks and PCs on your home network.



VAIO Media

MOVIES

Import videos from a Handycam*, trim and edit them, or export them to a Handycam* with DVgate Plus. Use Adobe® Premiere® Standard with VAIO Edit Components to add transitions and effects like sparkles. Multiple channel (4ch DV-AVI capture, 4ch/5.1ch DV-AVI output, etc.) surround sound is supported.

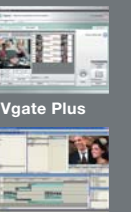

Adobe® Premiere® Standard

PHOTOS

Import images from your digital camera via USB cable or Memory Stick, then edit the files with Adobe® Photoshop® Elements. Use Photoshop® Elements. Use PictureGear Studio to place them in chronological order with Calendar View, create a slideshow, or create a photo album and print it or attach it to email.



PictureGear Studio

MUSIC

Import music from the Net or CDs with SonicStage. Then transfer it to a Network Walkman* or burn your own original CDs. SonicStage Mastering Studio lets you import analogue music (Roland EDIROL AUDIO capture UA-5* USB audio interface device required) and edit it with high-quality effector modules before recording on a CD. SonicStage Mastering Studio Audio Filter can enhance any sound played on VAIO and provides excellent headphone presets.



SonicStage Mastering Studio



SonicStage Mastering Studio Audio Filter



* Availability depends on region.
Note: Any copying or reproduction of copyrighted material may amount to copyright infringement. Song titles, names of artists and other information shown in the SonicStage screen capture are provided for illustrative purposes only.